

Turbine Flow Meter

StaTurb TF500 Series - High Performance

Introduction

StaTurb TF500 series column flow meter contains a magnetic detector and a magnetic turbine, which drives the turbine to rotate when the medium in the pipeline flows. The rotational speed of the turbine is directly proportional to the flow velocity of the medium. The magnetic detector detects the rotational speed of the rotor and converts it into a standard industrial electrical signal for output or display. It can be used for the measurement of medium and low viscosity media, such as water, solvent, hydraulic oil, lubricating oil, etc.



Characteristics

- High pressure rating
- Low pressure drop
- Fast response
- High repeatability and accuracy
- High / low temperature
- Compact design

Applications

- Petrochemical/Energy industry
- Hydraulic/Lubrication system
- Water treatment
- Oil/Gas industry
- Experimental equipment
- Test systems
- Food/Medical equipment

Specifications

Flow range	See below flow range table for details.
Applicable medium	Low to medium viscosity Liquids
Accuracy	0.5%
Repeatability	<0.1%
Pressure rating	Standard 5000psi (Customization available)
Response time	2ms (fastest)
Operating Temperature	-100...350°F (-75...175°C) High temperature model: up to 750°F (400°C)
Materials	Body: 316 stainless steel
	Rotor: 17-4 PH stainless steel
	Shaft: 316 stainless steel
	Bearing: stainless steel ball bearing / hybrid ceramic ball bearing
Process connection	MS male flare NPT male thread ASME B16.5 Flange

Flow Range - GPM

Part Code	Flow Meter Size	Standard Flow Range (GPM)		Extended Flow Range (GPM)		Filtration (Micron)
		Magnetic Pickup	RF Pickup	Magnetic Pickup	RF Pickup	
R-02	1/4"	0.13...1.3	0.13...1.3	0.11...1.45	0.01...1.45	10
R-04	1/4"	0.32...3.2	0.27...3.2	0.11...3.4	0.03...3.4	10
R-06	3/8"	0.53...5.3	0.5...5.3	0.13...6	0.06...6	10
R-08	1/2"	0.87...8.7	0.74...8.7	0.16...10	0.1...10	10
R-10	5/8"	1.6...16	1.2...16	0.3...19	0.2...20	10
R-12	3/4"	2.4...24	2...24	0.5...25	0.3...25	10
R-16	1"	5.8...58	5...58	1...65	0.65...65	20
R-20	1-1/4"	10...100	9...100	1.6...130	1.3...130	20
R-24	1-1/2"	18...180	15...180	2.6...210	2.1...210	50
R-32	2"	30...300	21...300	3.5...350	2.7...350	50
R-40	2-1/2"	40...400	35...400	5...450	4.5...450	50

Flow Range - LPM

Part Code	Flow Meter Size	Standard Flow Range (LPM)		Extended Flow Range (LPM)		Filtration (Micron)
		Magnetic Pickup	RF Pickup	Magnetic Pickup	RF Pickup	
R-02	1/4"	0.5...5	0.5...5	0.4...5.5	0.05...5.5	10
R-04	1/4"	1.2...12	1...12	0.4...13	0.13...13	10
R-06	3/8"	2.0...20	1.9...20	0.5...24	0.24...24	10
R-08	1/2"	3.3...33	2.8...33	0.6...38	0.38...38	10
R-10	5/8"	6...60	4.5...60	1.1...70	0.7...70	10
R-12	3/4"	9...90	7.6...90	1.9...95	1.2...95	10
R-16	1"	22...220	19...220	3.8...240	2.4...240	20
R-20	1-1/4"	40...400	34...400	4.9...490	4.9...490	20
R-24	1-1/2"	70...700	57...700	8.2...820	8.2...820	50
R-32	2"	110...1100	83...1100	13...1300	10...1300	50
R-40	2-1/2"	150...1500	150...1500	19...1700	17...1700	50

Pressure drop

Part Code	Pressure drop (% measuring range)						
	psi						
	10%	25%	40%	55%	70%	85%	100%
R-02	0 (0)	0.01 (0.15)	0.03 (0.44)	0.05 (0.73)	0.08 (1.16)	0.11 (1.6)	0.15 (2.18)
R-04	0.01 (0.15)	0.03 (0.44)	0.06 (0.87)	0.16 (2.32)	0.19 (2.76)	0.27 (3.92)	0.35 (5.08)
R-06	0.01 (0.15)	0.02 (0.29)	0.06 (0.87)	0.11 (1.6)	0.16 (2.32)	0.23 (3.34)	0.32 (4.64)
R-08	0.01 (0.15)	0.05 (0.73)	0.11 (1.6)	0.2 (2.9)	0.3 (4.35)	0.46 (6.67)	0.61 (8.85)
R-10	0.06 (0.87)	0.12 (1.74)	0.23 (3.34)	0.41 (5.95)	0.61 (8.85)	0.92 (13.34)	1.22 (17.69)
R-12	0.06 (0.87)	0.13 (1.89)	0.24 (3.48)	0.42 (6.09)	0.64 (9.28)	0.93 (13.49)	1.22 (17.69)
R-16	0.06 (0.87)	0.09 (1.31)	0.16 (2.32)	0.27 (3.92)	0.39 (5.66)	0.57 (8.27)	0.74 (10.73)
R-20	0.06 (0.87)	0.13 (1.89)	0.24 (3.48)	0.43 (6.24)	0.62 (8.99)	0.96 (13.92)	1.31 (19)
R-24	0.07 (1.02)	0.16 (2.32)	0.32 (4.64)	0.6 (8.7)	0.89 (12.91)	1.32 (19.15)	1.74 (25.24)
R-32	0.07 (1.02)	0.08 (1.16)	0.14 (2.03)	0.24 (3.48)	0.34 (4.93)	0.51 (7.4)	0.66 (9.57)
R-40	0.03 (0.44)	0.06 (0.87)	0.13 (1.89)	0.21 (3.05)	0.4 (5.8)	0.45 (6.53)	0.61 (8.85)

Following results were obtained by testing medium with a viscosity of 1.2mm²/s

Dimensions in mm

MS Connection

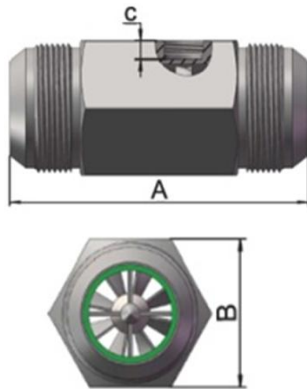

Part Code	Flow Meter Size	End Fitting MS Male Flare (Tube Size)	A	B	C
R-02	1/4"	1/2"	62.2	23	6.7
R-04	1/4"	1/2"	62.2	23	6.7
R-06	3/8"	1/2"	62.2	23	5.8
R-08	1/2"	1/2"	62.2	23	5.5
R-10	5/8"	5/8"	69.2	32	8.6
R-12	3/4"	3/4"	83	32	7.9
R-16	1"	1"	90.5	36	5.8
R-20	1-1/4"	1-1/4"	103	41	6.5
R-24	1-1/2"	1-1/2"	116.5	50	6.8
R-32	2	2	154	65	8.8

NPT Connection

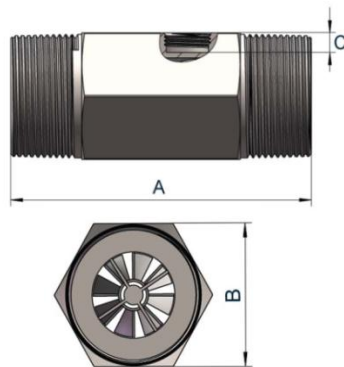

Part Code	Flow Meter Size	End Fitting NPT Male Thread	A	B	C
R-02	1/4"	1/2"	68	23	6.7
R-04	1/4"	1/2"	68	23	6.7
R-06	3/8"	1/2"	68	23	5.8
R-08	1/2"	1/2"	68	23	5.5
R-10	5/8"	3/4"	69.2	32	8.6
R-12	3/4"	3/4"	82.8	32	7.9
R-16	1"	1"	90.5	36	5.8
R-20	1-1/4"	1-1/4"	103	46	6.5
R-24	1-1/2"	1-1/2"	117	50	6.8
R-32	2	2"	155	65	8.8

Order Code

Example: TF500-R-10AS

1. Model

TF500- High Performance Turbine Flow Meter

2. Part Code

R-10 Select a part code from flow range table above to determine flow range.

3. End Fitting

M 37° MS Male Flare
 N Male NPT Thread
 Fxxx ASME B16.5 Flange (xxx: Class#)
 E.g., F600 for ASME Flange Class 600
 Other end fittings on request

4. Bearing

S Stainless steel ball bearing
 C Hybrid ceramic ball bearing

Electronics

1. Model

S1000- Electronics for turbine flow meter

2. Pickup

M Magnetic (standard)
 H Hall effect
 R RF

3. Output

P1 Pulse output
 P2 Linearized pulse output
 A Analog output
 D Digital transmitter
 E Ex-proof transmitter

4. Temperature

T1 -40...200°F (-40...100°C)
 T2 -40...300°F (-40...150°C)
 T3 -40...450°F (-40...230°C)

See electronics' datasheet for details

